

With 10 patents
pending!



VVI

Vertical intermittent
running side sealing
pouch

The VVI-highlights

- Motor driven format adjustment by pushing a button
- Flexible at format range - without size part change individual formats of 50-200 mm at bag heights of 80-260 mm and a volume from 15-1250 cm³
- Due to solid style remarkable less floor space as for horizontal machines
- Minimized downtimes at product change, since dosing screws can be removed for cleaning without dismantling the format set
- Highest quality for product and bag by closed system, optimised design and proved components
- Reduced packing costs, as all, even low-price heatsealable mono- and laminated packing materials from 20-20 µm can be used

Vertical 3-, 4-edge sealed
and free standing pouches
(RoPack®) produced from
a flat film reel!



Dosing
Pillow Bags
Cartoning
Final Packaging

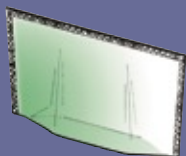

**VVI – Vertical 3-, 4-
edge sealed and
free standing
pouches (RoPack®)
produced from a
flat film reel!**

VVI Vertical intermittent running
side sealing pouch



ROVEMA
Verpackungsmaschinen GmbH
Industriestraße 1
D 35463 Fernwald
Tel: ++49-641-409-0
Fax: ++49-641-409-212
info@rovema.de
www.rovema.de

ROVEMA
Verpackungsservice GmbH
Industriestraße 3
D 35463 Fernwald
Tel: ++49-641-94 00 20
Fax: ++49-641-4 69 76
info@rvs-gmbh.de
www.rovema-verpackungsservice.de

ROVEMA
Verpackungsmaschinen Sp. Zo.o.
ul. Odynca 51
PL - 02-606 Warszawa
Tel.: ++48-22 844 7748
Fax: ++48-22 854 0446
postmaster@rovema.atomnet.pl

ROVEMA Iberica S.A.
C/Mas d'en Cisa, 5,
Apdo. Correos N0 55
E 08181 Sentmenat (Barcelona)
Tel: ++34-93-7 15 46 00
Fax: ++34-93-7 15 46 38
rovema@rovema.es

ROVEMA
Packaging Machines L.P.
650 Hurricane Shoals
Road NW, Lawrenceville,
GA 30045 U.S.A
Tel: ++1-770-5 13 96 04
Fax: ++1-770-5 13 08 14
rovema@rovema.com
www.rovema.com

ROVEMA
Packaging Machines Limited
The Coach House
The Firs, High Street
GB-Whitchurch, Aylesbury
HP 22 4 SJ
Tel: ++44-12 96-64 20 60
Fax: ++44-12 96-64 15 50
sales@rovema.co.uk

ROVEMA Benelux bv
Everdenberg 9, 4902 TT
Postbus 4357, 4900 CJ
NL Oosterhout
Tel: ++31-162-576 464
Fax: ++31-162-576 465
sales@rovema.nl

ROVEMA Italia s.r.l.
Viale P.O.Vigliani, 21
I 20148 Milano
Tel: ++39-02 48 01 17 85
Fax: ++39-02 48 00 82 59
rit@rovema-italia.it

The VVI system, with 10 patents pending, combines the various applications of horizontal machines with advantages offered by vertical form-, fill- and seal machines.

Optimal features

The combined system allows the compact and dust-free packaging also of very dusty products as well as the gas flushing of some products in the food branch, with a residual oxygen content of < 1%.

The standard execution with the vacuum draw down system ensures a secure packing material transport, including films thicker than 20 µm. Therefore, the seals can handle very flexible, soft, thin and stretchable packing materials without problems.

Programmable sealing times and the patented, wear-free cross sealing station with a sealing pressure up to 5000N provide the highest guarantee of bag quality.

High productivity and solid style

The format change by pushing a button, enables the effective production of different bag dimensions without complicated tooling requirements. Downtimes during product changeover are additionally minimized since dosing screws can be removed for cleaning, without dismantling the format set.

With a space requirement of only approx. 3,5 m² and a working height of approx. 1,5 m, the „complete execution“ with splicer, printing units, labellers, zip applicator, etc. is possible.

VVI performs with the high speed of between 100 bags/min. even at larger format sizes. The VVI system is easy and safely to operate with the control system ROVEMA P@ckControl.

The principle

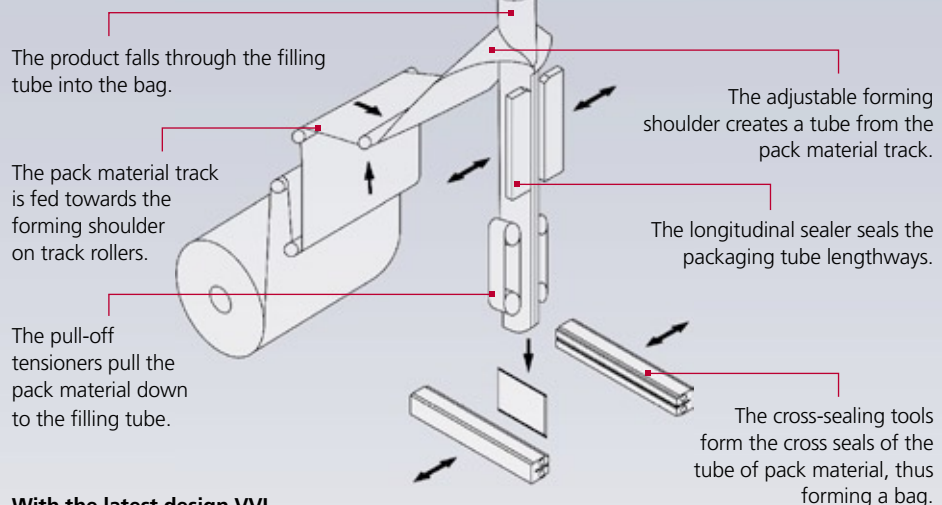

**With the latest design VVI -
the vertical intermittent running side sealing machine -
ROVEMA has further developed the scope of vertical form-,
fill and seal machinery.**